

OWNER'S MANUAL

**Ibanez**  
MULTI  
EFFECTS  
UE405

*Two copies only*

To get most out of the UE405 and to avoid unnecessary trouble, please read this manual before operating.

## FEATURES

- **4 in 1**  
Studio quality Compressor/Limiter, Stereo Chorus, Parametric EQ and Analog Delay combined into one compact unit. The UE-405 provides a wide variety of sound effects without hundreds of pounds of rack equipment.
- **Remoto FET Switching**  
Rugged, dependable footswitches control FET switches within the unit for noise free effect switching.
- **LED Indicators**  
Each effect and the master IN/OUT on the front panel and on the footboard, feature LEDs to indicate the status of the UE-405.
- **External Effects Jack**  
The UE-405 will accept any external effect and control switching from the Master footswitch.
- **Insta-Patch Selector**  
The patching sequence of the effects in the UE-405 can instantly be changed with the exclusive Insta-Patch selectors. These 5 position rotary switches let you place any effect in any of 5 positions in the series chain.
- **Stereo Chorus Output**  
The UE-405 Chorus is a high performance, invert phase type with individual outputs.
- **AC Power**  
All effects operate from a regulated DC supply.
- **Sound Quality**  
Each effect has studio quality designed in. Sound was not compromised for the sake of convenience.  
Each effect has low noise and low distortion.

## OPERATING PRECAUTIONS

- **Power Supply: 117VAC(T-TYPE) or 220-240VAC(R,U,Q & S-TYPE).**
- **Operate unit only if temperature is within the range of 0°C (32°F) to 40°C (104°F).**
- **The UE405 is constructed from precision parts. Do not allow liquids or other contaminants in contact with the unit.**
- **Do not plug or unplug AC power cord while using at loud volumes.**  
Amplifier or speaker damage may result.

## FRONT PANEL

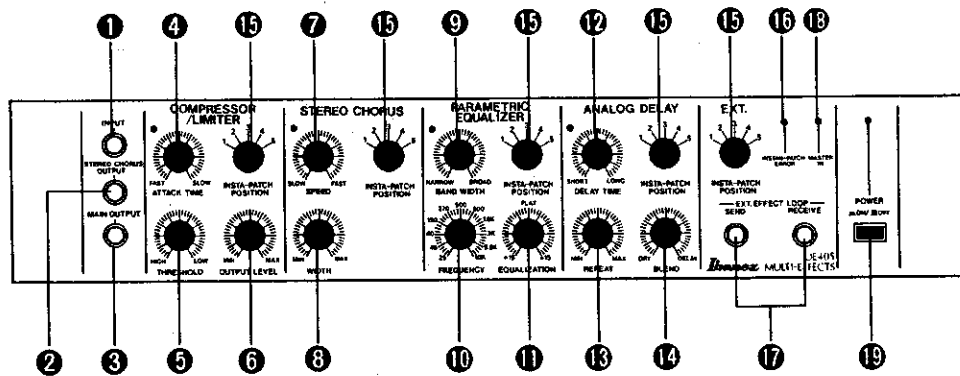

### 1 Input

Connects to instrument. If using mixer, connects to effects send jack of mixer.

### 2 Stereo Chorus Output

Separate output for Stereo Chorus only.

### 3 Main Output

Connects to amplifier or effects receive jack of mixer.

## Compressor/Limiter

### 4 Attack Time

CW,fast. CCW,slow.

### 5 Threshold

Sets trigger level of compression effect. CW, threshold level is high. CCW,low.

ex. When using as a compressor, set low for long sustain. When using as a limiter, set high for natural sustain.

### 6 Output Level

Controls the output level of the Compressor/Limiter. Usually set where the effect signal is the same as the normal level.

## Stereo Chorus

### 7 Speed

Controls sweep speed of Chorus effect. CCW (slow) is 3 times in 10 sec. CW (fast) is 3 times in 1 sec.

### 8 Width

Controls intensity of the sweep. Turning CW deepens the Chorus effect.

## Parametric EQ

### 9 Bandwidth

Varies the range of frequencies which is acted on by the EQ. At CCW, the range of frequencies EQ'd is narrow. Narrow band equalization is useful for hum cancellation or anti-feedback applications. In the CW position, the band of frequencies acted on is very broad. Broadband EQ is useful where it is desirable to add or remove tonal coloration.

### 10 Frequency

Controls the center frequency of the band to be EQ'd. Variable from 25Hz to 10KHz to cover the whole range of musical instrument applications.

### 11 Equalization

Varies the amount of cut and boost up to 15 dB.

## Analog Delay

### 12 Delay Time

Controls the amount of delay time. Variable from 10ms to 300ms.

### 13 Repeat

Controls the amount of regeneration in the delay section. On longer delays, controls the number of repeats. CCW is 1 repeat.

CW is infinite. On short delays, turning control CW may cause feedback.

- ④ Blend  
Adjusts the delay/dry mix. CCW is dry only. CW is delay only.
- ⑤ Insta-Patch Selectors  
Lets you place any effect in any of 5 positions in the series chain. Rotate the knob to the desired position and the effect is automatically connected internally.
- ⑥ Insta-Patch Error  
This LED flashes when 2 or more of the Insta-Patch Selectors are set on the same

number. The LED should also light momentarily when power is turned off.

- ⑦ External Effects Loop  
Connects SEND to the external effect input. Connects RECEIVE to the external effect output.
- ⑧ Master IN/OUT Indicator  
LED lights when effects group is on. When out, input signal is fed directly to the output.
- ⑨ Power Switch  
Push in to turn unit on or off.

## FOOTSWITCH

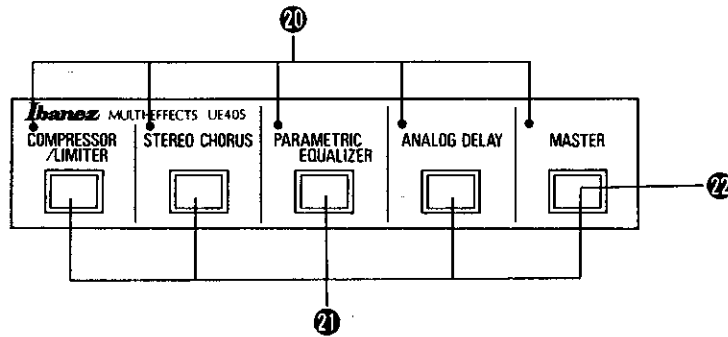

- ⑩ NORMAL/EFFECT INDICATOR  
A LED for each effect indicates effect or normal mode.
- ⑪ FET ELECTRONIC FOOTSWITCH  
Standard rugged dependable footswitches con-

trol FET switches within the unit for click free normal effect switching.

- ⑫ MASTER IN/OUT  
Master footswitch for all of the effects IN/OUT.

## CONNECTION DIAGRAMS

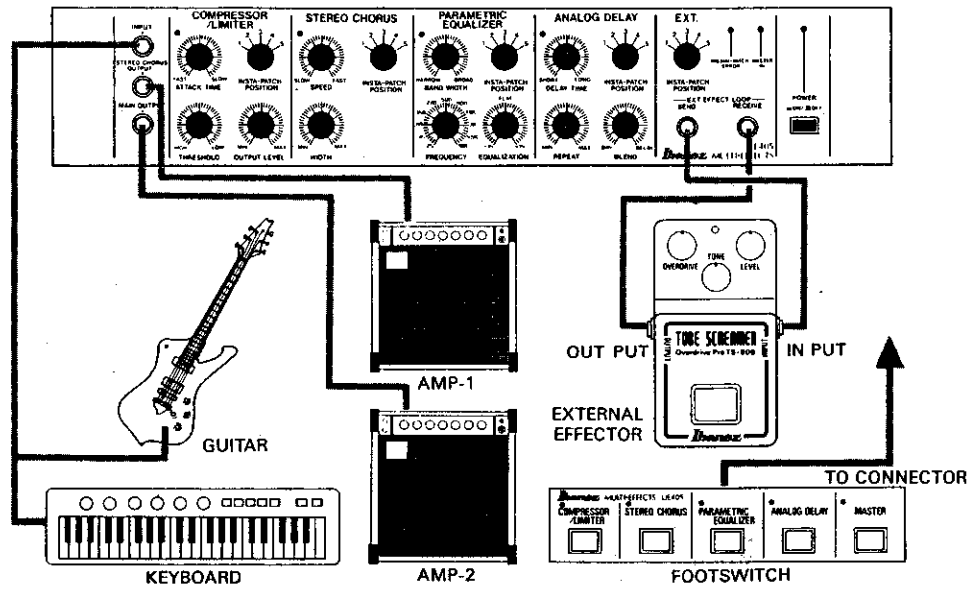

- 1) Connects footswitch cable and UE405.
  - 2) Connects instrument to input, amplifier to output.
  - 3) If you use another effectors, make chains of effects receive and send jacks, make sure switch is on effect. Use master footswitch for normal/effect switching of external effect.
- NOTE: Please take off jacks from receive and send while external effector is not to use.

## BLOCK DIAGRAMS

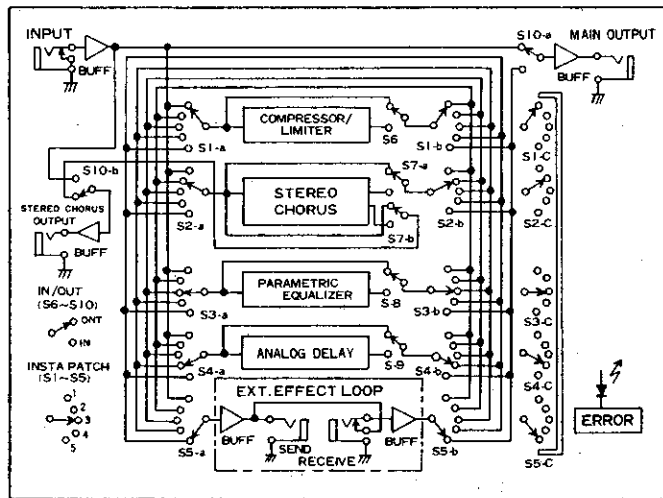

## 1) COMPRESSOR/LIMITER

Maximum Input Level	+6.5dBm at 400Hz
Maximum Output Level	0dBm at 400Hz
Output Level Range	-40dBm to 0dBm
Maximum Compression Ratio	40dB
Equivalent Input Noise	-90dBm (IHF-A Input Shorted)
Attack Time	6mSec. to 20mSec.
Frequency Response	30Hz to 20KHz (+5dB, -2dB)

## 2) CHORUS

Maximum Input Level	+5.6dBm at 400Hz
Delay Time	3.2mSec. to 8.5mSec.
Input:Output	1:1
Equivalent Input Noise	-106dBm (IHF-A Input Shorted)
Sweep Speed	0.3Hz to 3.0Hz

## 3) PARAMETRIC EQUALIZER

Maximum Input Level	+13dBm at 400Hz
Maximum Output Level	+13dBm at 400Hz
Equivalent Input Noise	-92dBm (IHF-A Input Shorted)
Band Width	7 oct. to 1 oct.
Frequency Control	25Hz to 10KHz
Level Control	±15dB

## 4) ANALOG DELAY

Maximum Input Level	+11dBm at 400Hz
Input:Output	1:1
Equivalent Input Noise	-98dBm (IHF-A Input Shorted)
Delay Time	10mSec. to 300mSec.
Delay Frequency Response	30Hz to 2KHz (+1dB, -3dB)

## 5) OVERALL

Input Impedance	500Kohms
Main Output Impedance	Less than 10Kohms
Stereo Chorus Output Impedance	Less than 10Kohms
External Effect Loop Send Impedance	Less than 10Kohms
External Effect Loop Receive Impedance	500Kohms
Power Requirements	
117V AC	60Hz, 7.0W
220V-240V AC	50Hz, 9.2W
Size	
Body	482(W) x 98(H) x 232(D)mm
Remote Footswitch	340(W) x 42(H) x 70(D)mm
Weight	
Body	3.9Kg, 8.6Lbs
Remote Footswitch	1.2Kg, 2.7Lbs
Accessories	
Remote Footswitch w/Connection Cord 5m	Included

\* Change without notice for improvement.